

INTERIOR VIEW: CUTTING WINDOW OPENINGS IN SHEATHING

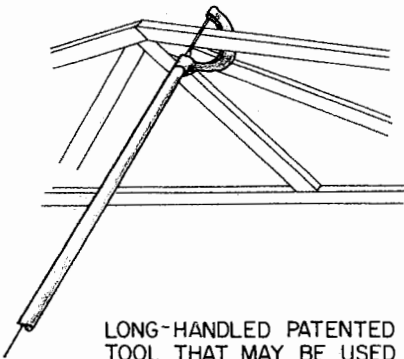

LONG-HANDLED PATENTED TOOL THAT MAY BE USED FOR HANDLING TRUSS-FRAMES.

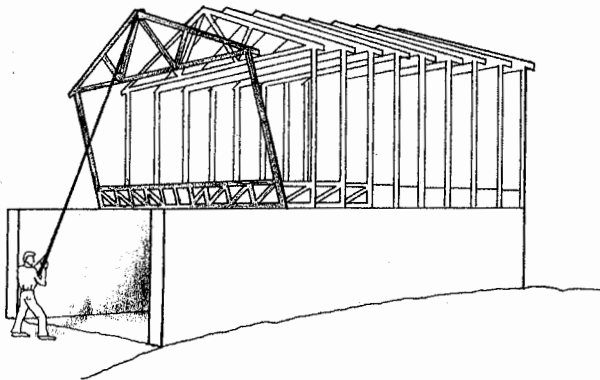

TILTING TRUSS-FRAMES IN PLACE

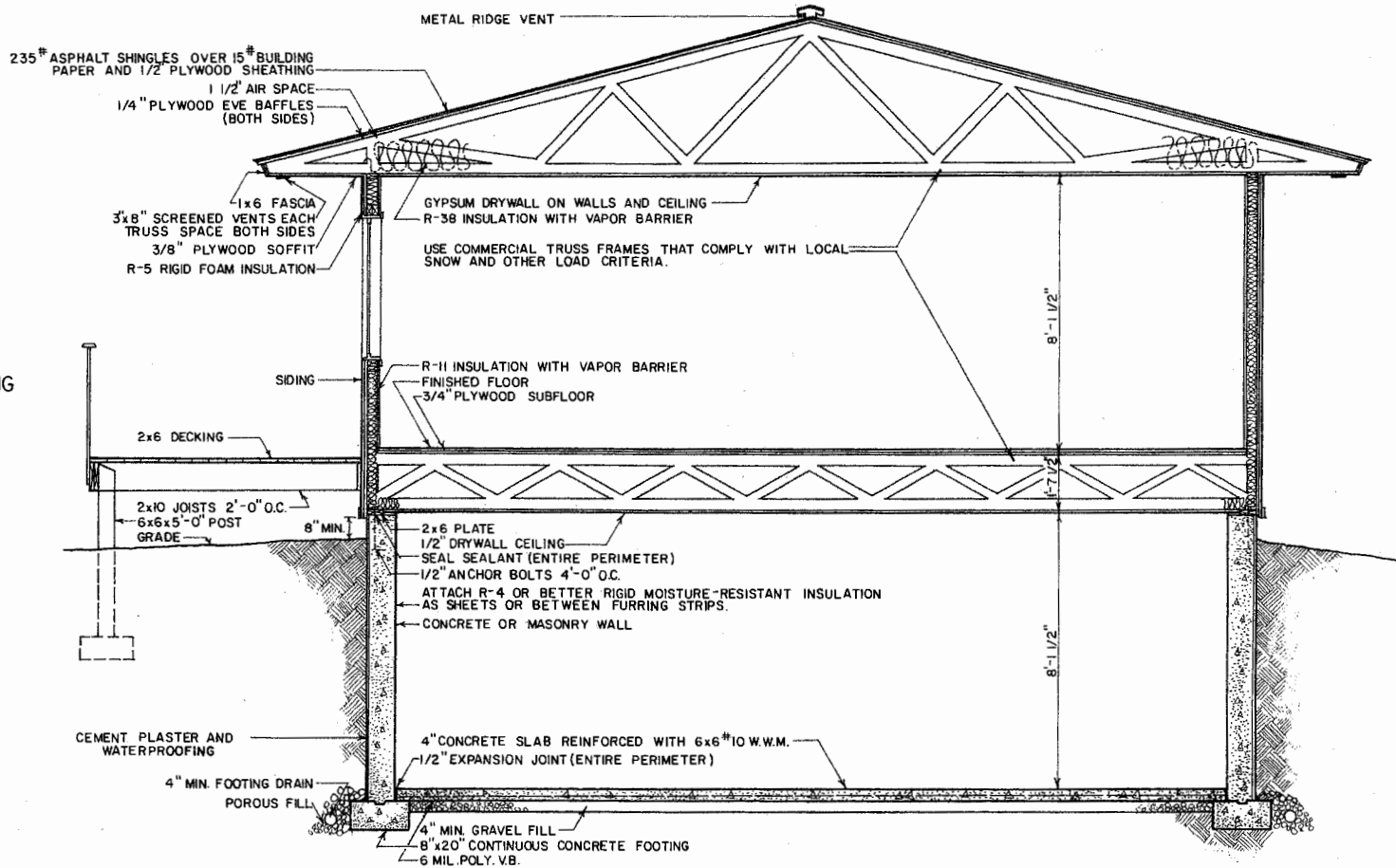

TYPICAL SECTION

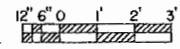

SCALE 3/8" = 1'-0"

(ALL OTHER DRAWINGS - NO SCALE)

ARRANGEMENT OF TRUSS MEMBER(S) MAY VARY WITH MANUFACTURER.

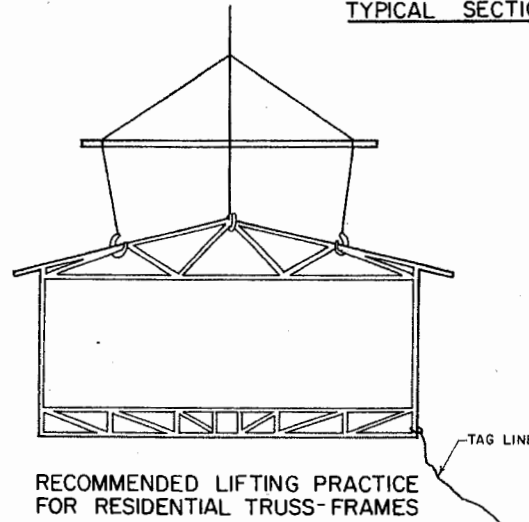

RECOMMENDED LIFTING PRACTICE FOR RESIDENTIAL TRUSS-FRAMES

ADAPTED FROM RESEARCH DEVELOPED BY THE FOREST PRODUCTS LABORATORY, FOREST SERVICE, USDA.



TRUSS FRAME CONSTRUCTION IN HOUSING

TYPICAL APPLICATION OF TRUSS FRAME CONSTRUCTION IN HOUSING

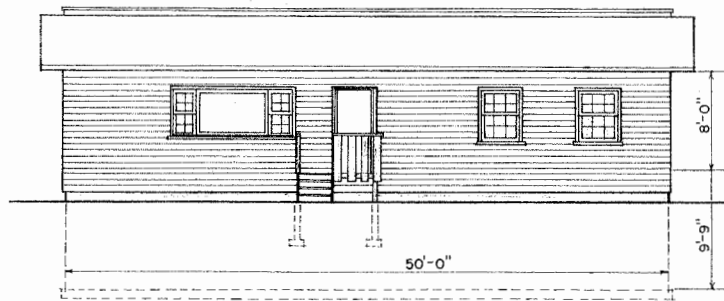

FRONT ELEVATION

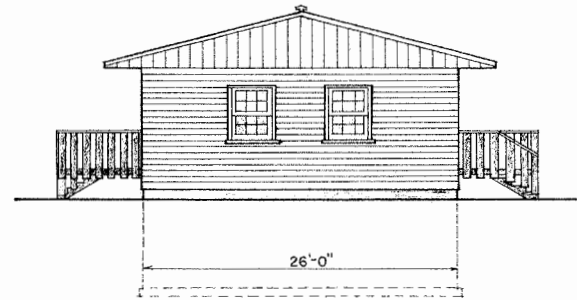

RIGHT ELEVATION

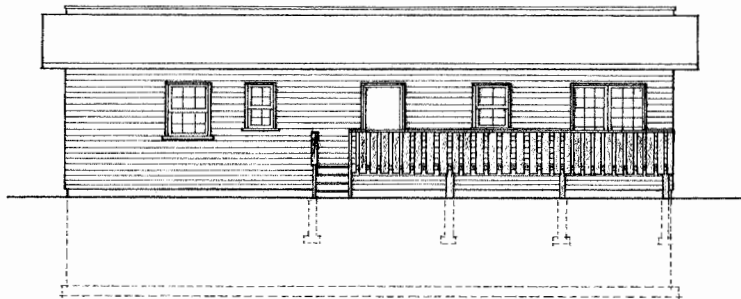

REAR ELEVATION

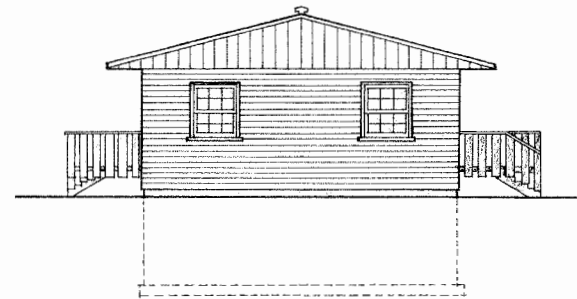

LEFT ELEVATION

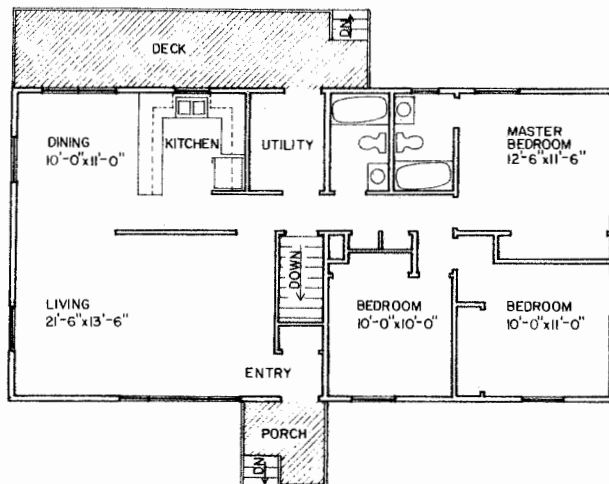

FLOOR PLAN

CONSTRUCTION CHECK LIST

1. CHECK LOCAL BUILDING CODE AND LOAN COMPANY CRITERIA.
2. ADEQUATELY NAIL AND ANCHOR JOINTS.
3. SHEATH CORNERS WITH 1/2" PLYWOOD OR HIGH DENSITY FIBERBOARD OR USE DIAGONAL BRACING.
4. USE EXTERIOR GLUED PLYWOOD WHEREVER IT MAY BE WETTED DURING OR AFTER CONSTRUCTION.
5. PRESSURE TREAT ALL WOOD WITH GROUND CONTACT AND PROVIDE OTHER NEEDED TERMITE CONTROL.
6. R VALUES DEPEND ON LOCAL CLIMATE AND FUEL COSTS.
7. PROVIDE 1 SQ FT OF ATTIC VENT OPENINGS FOR EACH 150 SQ FT OF CEILING.
8. WEATHERIZE ALL OPENINGS AND JOINTS.
9. THE COMPLETE FLOOR, WALL, AND ROOF TRUSS SYSTEM WILL NORMALLY BE CONSTRUCTED BY A TRUSS MANUFACTURER. THE THREE COMPONENTS MAY BE ASSEMBLED AT THE FACTORY OR ON SITE.
10. NORMALLY, THE BUILDING WILL BE COMPLETELY SHEATHED BEFORE LOCATING WINDOWS AND DOORS.
11. INSTALL HEADERS FOR WINDOWS AND DOORS BEFORE CUTTING OPENINGS IN SHEATHING AND STUDS. HEADERS ARE NOT NEEDED WHEN WINDOWS FIT BETWEEN STUDS, LESS THAN 22 1/2" WIDE.

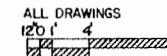

SCALE 1/8" = 1'-0"

TRUSS FRAME CONSTRUCTION IN HOUSING		
USDA'85	7261	SHEET 2 OF 3

OTHER EXAMPLES OF FLOOR PLANS

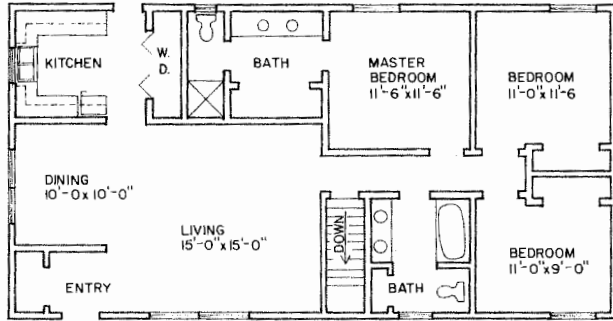

ALTERNATE A: 50'x26', 3 BEDROOM - 2 BATH

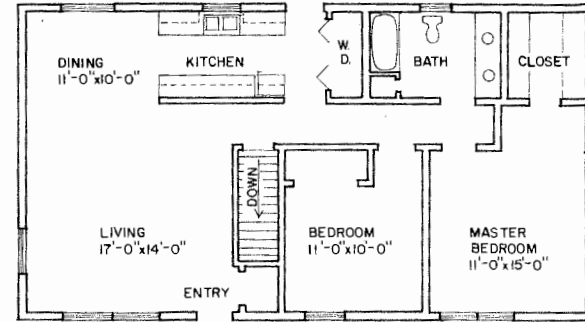

ALTERNATE D: 48'x26', 2 BEDROOM - 1 BATH

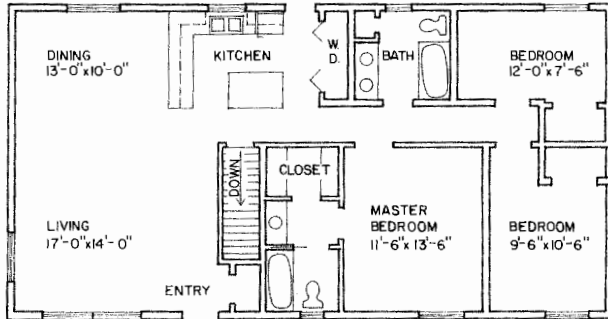

ALTERNATE B: 50'x26', 3 BEDROOM - 2 BATH

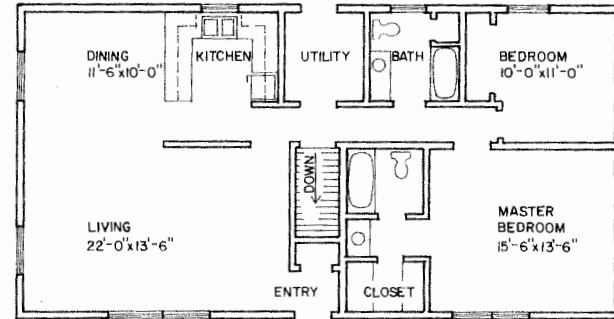

ALTERNATE E: 50'x26', 2 BEDROOM - 2 BATH

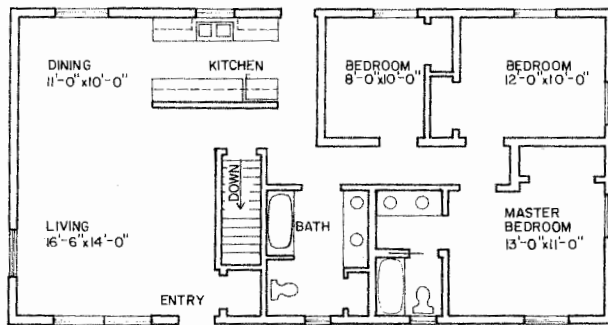

ALTERNATE C: 50'x26', 3 BEDROOM - 2 BATH

THERE ARE MANY VARIATIONS IN FLOOR PLANS THAT CAN BE WORKED OUT WITH THIS BASIC FRAMING CONCEPT. KEEP IN MIND THAT THE TRUSS MAY BE CONSTRUCTED IN WIDER WIDTHS THAN SHOWN AND THAT THE HOUSE LENGTH CAN BE CHANGED BY INCREMENTS OF 2 FEET. BASEMENT ACCESS IS SIMPLIER TO CONSTRUCT WHEN ONLY ONE FLOOR TRUSS NEEDS TO BE CUT. PLAN WINDOWS TO FIT BETWEEN TRUSSES SO THAT THE FEWEST POSSIBLE TRUSSES NEED TO BE CUT. WHEN SELECTING ROOM LOCATIONS CONSIDER TRAFFIC FLOW BETWEEN ROOMS, CONVENIENCE FOR BRINGING IN FOOD OR DOING LAUNDRY, PRIVACY OF SLEEPING AREAS AND BATH, AND ORIENTATION OF WINDOWS WITH RESPECT TO SUN, AIR MOVEMENT AND VIEW.

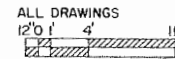

SCALE 1/8" = 1'-0"

LSU
AgCenter
Research & Extension

TRUSS FRAME CONSTRUCTION
IN HOUSING

USDA '85

7261

SHEET 3 OF 3

Disclaimer

This site makes available conceptual plans that can be helpful in developing building layouts and selecting equipment for various agricultural applications. These plans do not necessarily represent the most current technology or construction codes. They are not construction plans and do not replace the need for competent design assistance in developing safe, legal and well-functioning agricultural building system. The LSU Agriculture Center, the Mid-West Plan Service, the United States Department of Agriculture and none of the cooperating land-grant universities warranty these plans.